

Application for Approval as Safe Community in the World Health Organization's Network of Safe Communities



Yayuncun Community

Beijing · China



Contents

1. Yayuncun Community

1.1. Introduction

1.2. Community Structure

1.3. Community Construction

2. WHO's indicators for Safe Community

3. Indicator 1

An infrastructure based on partnership and collaborations, governed by a cross-sectional group that is responsible safety promotion in their community

4. Indicator 2

Long-term, sustainable programs covering genders, all ages, environments and situations

4.1. Public Security

4.2. "Fire Control Safety Entering into Community"

4.3. "Traffic Safety Entering into Community"

4.4. Anti Domestic Violence

4.5. Home Safety

4.6. Community Cultural and Sports Activity Center

4.7. Improving Road Safety

4.8. Building Quiet Residential Districts

4.9. Safe Production

4.10. Community Disputes Intermediation

4.11. Psychological Consultation Service

4.12. Popularization of Public Hygiene and Home First Aid

4.13. Medical Waste disposal

5. Indicator 3

Programs that target high-risk groups and environments and programs that promote safety for vulnerable group

5.1. Safety Education For Youngsters and Children

5.2. Youth Reproductive Health Education

5.3. Elderly Health Promotion Center

5.4. Special Attention to the Elderly

5.5. “Warm Home” for the Handicapped

5.6. Healing Guidance for the Handicapped

5.7. Non-obstacle Facilities Construction

5.8. Migrants Education

5.9. Attention to Low Income Groups & Social Assistance

6. Indicator 4

Program that document the frequency and causes of injuries

6.1. Injury Records

6.2. Injury Surveillance

6.3. Home Water, Electric and Gas Use Safety Interview

7. Indicator 5

Evaluation measures to assess their programs, processes and the effect of change;

8. Indicator 6

Ongoing participation in national and international Safe Communities networks

9. Objectives of Sustainable Promotion in accord with Safe Community Indicators

Preface

**Dear Collaborating Centre on Community Safety Promotion
World Health Organization (WHO)
Dear Prof. Leif Svanstrom,**

Yayuncun community launched the project of Safe Community construction on October 2004 in accordance with international criteria. The mission of the Safe Community project is to seek a community safety mechanism in line with Chinese national situation and to reduce accidents and injury cases to the largest extent.

We conducted safety survey among residents and set priority on traffic injury and traffic prevention targeting at children and the elderly. We gave publicity to road safety, reconstructed community roads and parking environments, conducted fire control safety education and rebuilt fire equipment. The obvious results of our promotion work clearly indicated the effectiveness of community accidents and injury prevention. On April, 2005, community representatives attended the Safe Community Lecture by Mr. Leif Svanstrom, Head of WHO Collaborating Centre on Community Safety Promotion. On October 2004, the Project of Safe Community Construction was inaugurated in Yayuncun Community.

Since the kicking off of the Safe Community project, Yayuncun Community firstly set up Safe Community Promotion Committee to take charge of safety promotion, coordination and evaluation. We maintained close partnership with China Occupational Safety and Health Association and Economy and Business School, China Chemical University. Experts from these institutes were invited to hold lectures in Yayuncun community to explain and spread the “Safe Community” concept, to introduce injury supervision measures and to provide guidance in making safety promotion programs and injury preventative measures. With the direct support and assistance of Chaoyang District People’s Government, the project of Safe Community construction in Yayuncun has been steadily pushing forward in accordance with WHO’s indicators.

Composition of Yayuncun Safe Community Committee includes representatives from Community Office, neighborhood committees, Community Service Center, Community Cultural and Sports Center, Yayuncun Police Station of Chaoyang District Public Security Bureau, Yayuncun Detachment of Chaoyang District Traffic Police Brigade, Yayuncun Detachment of Chaoyang District Fire Company, enterprises, schools and volunteers organizations. Under the Promotion Committee, 9 working groups were formed, namely, road safety, fire control safety, home safety, social stability, occupational safety and health, child safety, sports safety, environment and public hygiene safety, and community diagnosis, surveillance and evaluation. The tasks of working groups are to develop programs, set up objectives of different stage, take charge of daily safety work in different fields, review late works, find out deficiencies and adjust working methods so as to achieve the smooth implementation of the project of Safe Community construction.

To reduce accidents and injuries to the largest extent, we conducted accidents and injuries prevention in the whole community with the leadership of Safe Community Promotion Committee from October 2004. Safety promotion programs cover genders, all ages, environments, and target children, the elderly, the handicapped and vulnerable groups. Yayuncun Community takes elderly safety promotion, child safety initiation, traffic safety promotion and road reconstruction, fire prevention, domestic violence and assistance for the handicapped as priorities of accidents and injury prevention, and extends promotion program in other fields in order to create the climate of safety promotion in the whole region.

Residents' awareness of safety has been generally raised with the publicity to Safety Community concept, education and training programs. Safety status and environment has been incessantly improved with the implementation of safety promotion programs and injury prevention measures.

Yayuncun Community participated in many national and international Safe Community networks, such as, Safe Community Construction Experience Exchange Meeting on April 2005 in Beijing, Safe Community Criteria and Implementation Symposium On October 2005 in Beijing, Designation Ceremony of Youth Park Safe Community & National Safe Community Symposium on March 2006 in Jinan, the 16th Safe Communities Conference on April 2006 in Africa, National Safe Community Construction Conference on September in Beijing. We also organized the investigation to Tai po and Kwai Tsing Safe Communities in Hong Kong, Youth Park Safe Community in Jinan City, Shangdong Province. Meanwhile, we also hosted the visiting delegation of Mr. JOON PIC CHO, Chairman of WHO Safe Communities Networks of Asia, and Deng Huasheng, Secretary General of Hong Kong Occupational Safety and Health Bureau.

To further carry out accident, injury and violence preventions in community, Yayuncun developed sustainable promotion program according to indicators set up by Collaborating Centre on Community Safety Promotion, World Health Organization (WHO). We will continue to make unremitting efforts on Safe Community promotion.

Therefore, we earnestly put forward this application to World Health Organization and hope to be approved as Safe Community in the World Health Organization's Network of Safe Communities. We are looking forward to enjoying more opportunities to strengthen accident, injury and violence preventions and achieving the stable and healthier progress of Safe Community project in Yayuncun Community.

Sincerely yours

Yang Shuqi
Director of Yayuncun Community Office

1. Yayuncun Community



1.1. Introduction

Located in the northeast of Chaoyang District, Yayuncun Community borders on Haidian District on the west, Olympic Village District and Datun District on the north, Xiaoguan Community on the east and Anzhen District on the south. As the core of functional district for 2008 Beijing Olympic Games, it is surrounded by National Stadium and National Olympic Sports Center. It contains China Nationality Garden, the largest minorities Museum in China, Beijing Yuan Dynasty City Wall Relics Park that symbolizes Chinese ancient civilization, Olympic Games Competition Venue, Zhonghua Nationalities Garden, and Zhongguacun Jianxiang Science Park. Beijing will hold the 29th Olympic Games. 7 Olympic venues of 32 are settled in Yayuncun Community. With beautiful environment, completed facilities, advanced transportation and convenient life, Yayuncun Community is known as a modern urban district area with integrated function of living, culture and sports, tour and trade.

Yayuncun Community enjoys advanced science and technology and strong cultural climate. It is facilitated with six kindergartens, six primary and high schools, nine junior colleges and institutes such as Micro-electronics Institute of CAS, Geological Research Institute of Chinese Earthquake Bureau, Chinese Music Academy, China Communication Engineering University, etc. It also comprises first groups of demonstration education centers designated by Beijing Education Committee, Elderly Health and Safety Promotion Center and Community Cultural and Sports Center Activity Center covering 2,600 square meters.

1.2 Population Profile

By the end of 2005, Yayuncun Community has 16,326 households with the total population of 47,205 (Male: 24,672; Female: 22,533).

Age Profile of Permanent Residents by Age (See table below)

| Age | 0 - 5 | 6 - 12 | 13 - 16 | 17 - 29 | 30 - 60 | 61 - 79 | 80 above |
|--------|-------|--------|---------|---------|---------|---------|----------|
| Number | 1338 | 1529 | 1053 | 9849 | 23852 | 8825 | 759 |

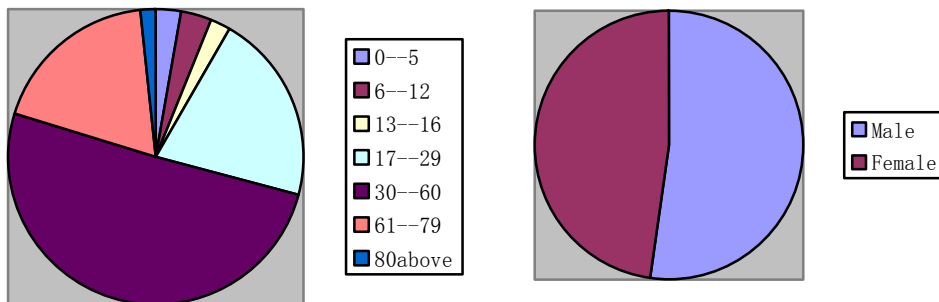

Age and Gender Proportion Profile

1.3. Community Organizations

Yayuncun Community Office (YCO) is the fundamental government organization for local residents and responsible for carrying out the overall community work. Composition of Community Office includes Administration Sector Office (ASO), Public Security Comprehensive Management Sector Office (PSCMSO), Community Construction Sector Office (CCSO), Population and Family Planning Sector Office (PFPSO), Urban Construction Management Sector Office (UCMSO), Publicity Sector Office (PSO), Labor Sector Office (LSO), Civil Administration Sector Office (CASO), Judicial Sector Office (JSO), City Management Supervision Unit (CMSU), Women’s Federation (WF), The Handicapped Association (THA), etc. These departments takes on many specific promotion program for the project of Safe Community construction.

Organizational Chart of Yayuncun Community Office

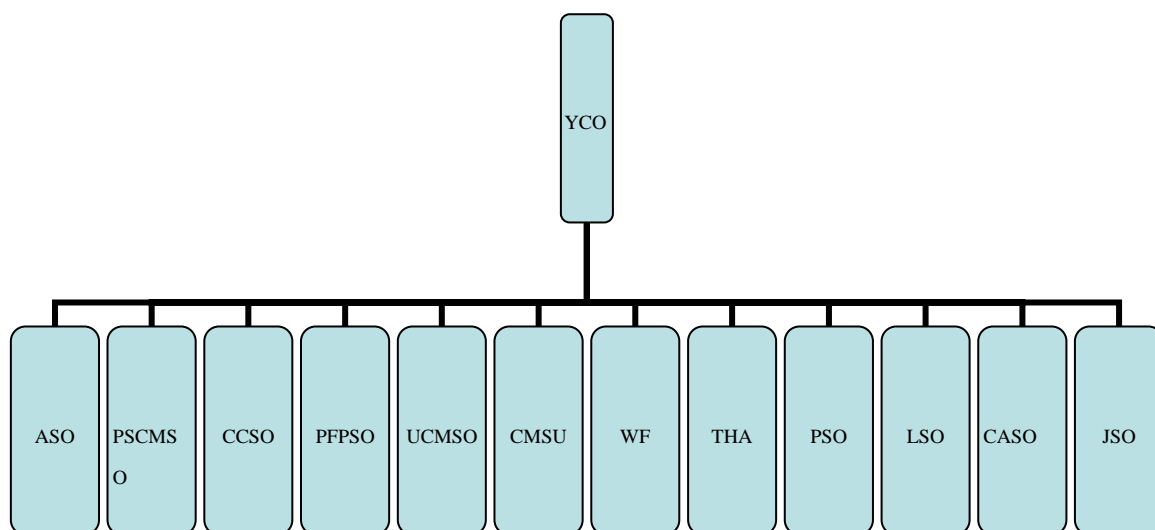

Yayuncun Community is divided into ten residential districts, namely, Anyuanli, Anhuilinan, Anhuili, Beichengdonglu, Shijiahuozhi, Anxiangli, Shizhuyuan, Huayanbeili, Huayanbeilixi and Jingmin. Each residential district has neighborhood committee with members voted by residents. It is a self-governance, self-education and self-service organization.

Organizational Chart of Yayuncun Neighborhood Committees

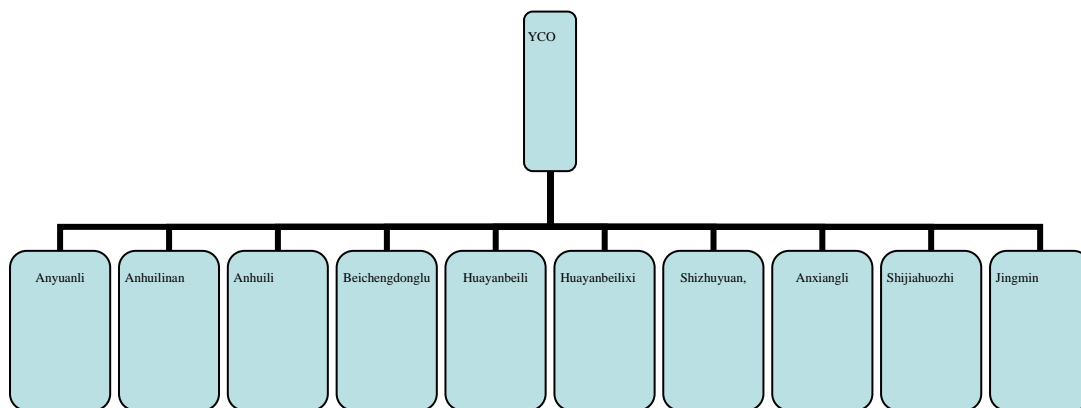

Yayuncun Police Station is one of administrative arms of Chaoyang District Public Security Bureau and responsible for public security in Yayuncun Community.

Yayuncun Community Fire Control Committee conducts fire control safety supervision and management, sets up fire control safety emergency mechanism, promotes fire control knowledge publicity and holds safety trainings. Community Fire Brigade takes charge of fire control safety publicity, equipment and facilities inspection, implementation of fire control measures for residential districts and social units, rushes to extinguish fires immediately and reduces human injury and property loss to the minimal size.

Yayuncun Community Traffic Safety Committee is in charge of giving publicity to traffic safety, raising residents and traffic participants' awareness of observing traffic regulations, inspecting vehicle safety capability and improving traffic environment.

Yayuncun Hospital holds the responsibilities of integrating medical resources for residential districts, promoting medical care knowledge and delivering medical services. Under the hospital, four neighborhood health care stations were formed, in which Huayanbeili is the first four-star health care station in Beijing and Beicheng is the three-star health care station.

Yayuncun Community Service Center and Community Cultural and Sports Center jointly promote health education and diseases prevention; conduct psychological consultation and health examination, safety and health knowledge education; and organizes community cultural and sports activities.

Yayuncun Community Handicapped Association, Women's Federation, Social Security Bureau and other institutions make concerted efforts on the handicapped's healing, women's rights protection, domestic violence countermeasures and assistance for low income and vulnerable groups.

Representatives from large-scale units in Yayuncun Community actively participated in the project of Safe Community construction.

The Inauguration Ceremony of the Project of Safe Community Construction in Yayuncun Community



1.4. Community Construction

- 1.4.1. Yayuncun Community has beautiful and clear environment and perfect community service functions. In recent years, Community Working Committee, Community Office completed the reconstruction for six elegant streets of Huizhonglu, Andinglu, Anyuan, Beiyuan, Beichengxilu and Beiyinanlu. It has built the green area of ten thousands meters in the middle axis line and high-grade green residential districts such as Anhui, Anyuanli, etc.
- 1.4.2. Yayuncun Community has advanced science and technology and strong cultural climate. It is facilitated with nine junior colleges and institutes such as Micro-electronics Institute of CAS, Geological Research Institute of Chinese Earthquake Bureau, Chinese Music Academy, Chinese Communication Engineering University, etc. It also comprises first groups of demonstration education centers designed by Beijing Education Committee and Community Cultural and Sports Center covering the area of 2,600 square meters. There are over 70 performance groups with different characteristics. They hold community holiday, green volunteers action, Greeting Olympic Games, civic virtues education, culture square and other activities that are welcomed by residents and create scientific, civilized and healthy living environment for residents in the region.
- 1.4.3. Economy in the region enjoys flourishing growth. Yayuncun Community not only has the advantage in tour service represented by Beijing International Convention Center, Beijing Continental Grand Hotel and Yuyuncun Hotel but also has superiority in developing community culture and sports. Every year community hosts more than 2,000 receptions for visiting and sighting tours both home and aboard. With such strong economic strength, excellent investment environment and perfect service facilities, Yayuncun Community has become the first choice for most investor.
- 1.4.4. Yayuncun Community has advantaged regional development resources and superiority. In accord with its objectives of creating beautiful environment, good social order, convenient life and harmonious human relationship, community has made unremitting efforts on civilization construction and built ideal humanistic,

living, developing environments and good city appearance. It is the core region for 2008 Beijing Olympic Games. Major part of Zhongguacun Jianxiang Science Park is also settled in the region. It contains it is surrounded by National Sports Venue and National Olympic Sports Center. It contains China Nationality Garden, the largest minorities' museum in China, National Olympics Sports Center, the most concentrated, completed and modern sports place.... In a word, Yayuncun Community serves as the window of Chanyang, Beijing and even China.

2. Indicators for Establishing Safe Community

Yayuncun developed sustainable promotion program according to six indicators set up by Collaborating Centre on Community Safety Promotion, World Health Organization (WHO).

- I. An infrastructure based on partnership and collaborations, governed by a cross-sectional group that is responsible safety promotion in their community;
- II. Long-term, sustainable programs covering both genders, all ages, environments and situations;
- III. Programs that target high risk groups and environments and programs that promote safety for vulnerable group;
- IV. Program that document the frequency and causes of injuries;
- V. Evaluation measures to assess their programs, processes and the effect of change;
- VI. Ongoing participation in national and international Safe Communities networks.

3. Indicator 1

Forming an infrastructure based on partnership and collaborations, governed by a cross-sectional group that is responsible safety promotion in their community;

Yayuncun Safe Community Promotion Committee was formed with the import of "Safe Community" concept in 2004.

Organizational Chart of Yayuncun Safe Community Promotion Committee

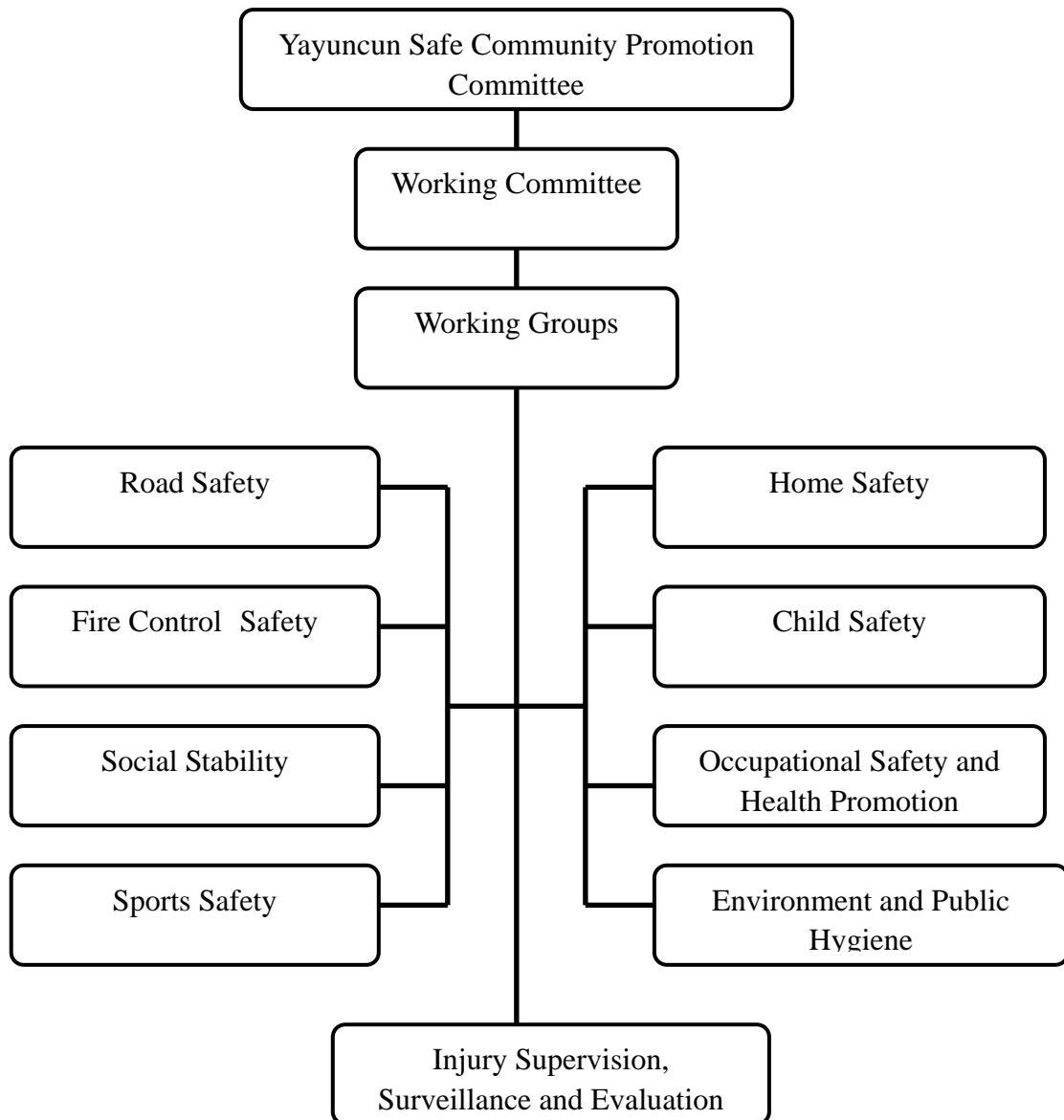

Safe Community Promotion Committee is responsible for conducting exchange and cooperation, exploring resources, setting up objectives, supervising and assessing promotion programs and the effects of changes.

Members of Safe Community Promotion Committee is made up of representatives from Yayuncun Community Office, ten Neighborhood Committees, Community Health Care Stations, Community Cultural and Sports Center, Yayuncun Police Station of Chaoyang District Public Security Bureau, Yayuncun Detachment of Chaoyang District Traffic Police Brigade, Yayuncun Detachment of



Chaoyang District Fire Company, enterprises, schools, volunteers organizations, and experts.

Directors and Experts of the Promotion Committee are tasked to supervise, examine and access the processes of Safe Community programs. With the close cooperation with China Occupational Safety and Health Association and Economy and Management School of China Chemical University, Yayuncun community formulated *Yayuncun Safe Community Promotion Proposal* and organized trainings that target the project of Safe Community construction by many times.

Composition of Yayuncun Safe Community Promotion Committee

Director:

Yang Shuqi, Secretary of Yayuncun Community Working Committee
Zheng Xia, Director of Yayuncun Community Office

Specially Invited Experts:

Yao Fei, Dean of Economy and Management School of China Chemical University
Ouyang Mei, Senior Engineer of China Occupational Safety and Health Association

Deputy Directors:

Zhao Guozeng, Deputy Director of Yayuncun Community Office
Zhao Yanxiang, Armed Force Sector Office of Yayuncun Community Office
Zhao Lijun, Deputy Director of Yayuncun Community Office
Yue Weihong, Deputy Director of Yayuncun Community Office
Dong Huisheng, Deputy Director of Yayuncun Community Office
Jie Zheng, Director of Yayuncun Residence Police Station
Liu Changjun, Director of Yayuncun Public Security Police Station
Luo Zhirong, Captain of Yayuncun Detachment of Chaoyang District Traffic Police Brigade
Shu Weijia, Captain of Yayuncun Detachment of Chaoyang District Fire Company
Zhao Heping, Captain of Yayuncun Fifth Supervision Team
Zhang JiuHong, Director of Yayuncun Subbranch, Chaoyang Branch of Beijing Industrial and Commercial Administrative Bureau

Members:

Li Jing, Director of Public Security Comprehensive Management Sector Office, Yayuncun Community Office
Hao Guoliang, Director of Administration Sector Office, Yayuncun Community Office
Deng Cheng, Director of Administration Sector Office, Yayuncun Community Office
Li Shuangsheng, Director of Judicial Sector Office, Yayuncun Community Office
Zhao Jianhong, Sector Chief of Civil Administration Sector Office, Yayuncun Community Office

Li Jie, Deputy Executive Head of Yayuncun City Management Supervision Unit,
Yayuncun Community Office
Li Xinyu, Vice Sector Chief of City Construction Sector Office, Yayuncun
Community Office
Zhao Guoyun, Deputy Director of Population and Family Planning Sector Office,
Yayuncun Community Office
Duan Biao, Vice Sector Chief of Labor Sector Office, Yayuncun Community Office
Shen Yishan, Vice Secretary of Beicheng Industry Group
Wang Hanning, Vice Secretary of Party Committee, Changkong Machine Co., Ltd.
Lu Qi, Vice Dean of Beijing Academy of Science
Liu Shanquan, Deputy Director of National Olympic Games Sports Center
Han Huanzhang, Deputy of Oil and Chemical Management Cadre College Subsection
Zhao Liping, Vice Secretary of China Music Academy
Zhu Jiakai, Vice General Manager of Shiqing Environment Sanitation Group
Wu Changcheng, Chairman of the Seventh City Management Company
Chen Feng, General Manager of Beicheng Xingcheng Property Company
Lian Ping, Vice General Manger of Jingmin Mansion
Lin Lejun, Vice General Manger of Foreign Experts Mansion
Yang Xiaofeng, Deputy Director of Geological Research Institute of Chinese
Earthquake Bureau
Gao Jinhong, Vice Dean China Communication Engineering University
Li Yugang, Director of Property Department, Mines Mansion
Guo Wenzhi, General Manage, Secretary of Party Committee of Beicheng Xinghe
Property Company
Yu Meng, Manager of Management Department of Huatingjiayuan Property Company
Ma Shouzeng, Manager of Hualongda Property Company
Wang Xiaobo, Vice General Manager of Beicheng Shopping Center
Zhang Xinxian, Manager of Yuanda Property Co., Ltd
Zong Shuting, Dean of Yuyuncun Hospital
Zhao Jinguo, Director of Beiyu Property Company
Zhao Junxing, Secretary of Party Committee of Anhuili Neighborhood Committee
Huang Li, Secretary of Party Committee of Anhuilinan Neighborhood Committee
Bao Hua, Secretary of Party Committee of Anyuanli Neighborhood Committee
Li Heping, Secretary of Party Committee of Shijiahuozhi Neighborhood Committee
Wang Gang, Secretary of Party Committee of Huayanbeili Neighborhood Committee
Li Yuehua, Secretary of Party Committee of Huayanbeilixi Neighborhood Committee
Zhang Liping, Secretary of Party Committee of Jingmin Neighborhood Committee
Gong Jinghua, Secretary of Party Committee of Shizhuyuan Neighborhood
Committee
Jiang Baoxiu, Secretary of Party Committee of Anxiangli Neighborhood Committee
Shi Linbin, Secretary of Party Committee of Beichengdonglu Neighborhood
Committee

Responsibility of Yayuncun Safe Community Promotion Committee

- I. To develop objectives of establishing Safe Community in light of community actual situation.
- II. To set up rules and regulations on Safe Community management.
- III. To organize meetings of the Promotion Committee and promote the sustainable implementation of Safe Community programs
- IV. To organize and coordinate resources and forces inside and outside community that can be integrated and utilized; to provide guidance for each working groups in collecting resources from governments and non-government organizations.
- V. To resolve difficulties in the process of construction and promote the smooth implementation of Safe Community project.
- VI. To coordinate and guide all working group to effectively carry out annual work plans.
- VII. To conduct examination and evaluation on the implementation of safety programs.
- VIII. To maintain and incessantly perfect the contents of Safe Community construction.
- IX. To organize the participation in national and international Safe Community networks.

Safe Community Working Committee was set up as the executive arm of the Promotion Committee to undertake daily management, contact and coordinate working groups.

Working Committee carries out the responsibilities for implementing safe promotion programs and mapping out measures that target high-risk groups and environments and valuable groups. Following the direction of the Promotion Committee, Working Committee integrates resources, makes joint efforts on planning and organizing activities among working groups and reviews programs implementation and evaluation in order to achieve the sustainable safety promotion.◦

Under the Working Committee, 9 working groups were formed.

- Working Group on Road Safety
- Working Group on Fire Control Safety
- Working Group on Social Stability
- Working Group on Sports Safety
- Working Group on Child Safety
- Working Group on Home Safety, Hygiene & Health
- Working Groups on Occupational Safety and Health
- Working Group on Environment and Public Hygiene
- Working Group on Injury Supervision, Surveillance and Evaluation

Each working group takes charge of own responsibilities and conducts mutual cooperation and concerted efforts on implementing safety promotion for the community.

Composition of Working Groups

- I. Members of Road Safety Working Group includes representatives from Yayuncun Traffic Police Brigade, Traffic Safety Committee, Public Security Comprehensive Management Sector Office, major service organizations, enterprises, property companies, neighborhood committees, volunteers, etc.
- II. Members of Fire Control Safety Working Group includes representatives from Yayuncun Traffic Police Brigade, Traffic Safety Committee, Public Security Comprehensive Management Sector Office, major service organizations, enterprises, property companies, neighborhood committees, volunteers, etc.
- III. Members of Social Stability Working Group includes representatives from Public Security Comprehensive Sector Office, Judicial Sector Office, police station, property companies, neighborhood committee, etc.
- IV. Members of Sports Safety Working Group include representatives from Community Construction Sector Office, National Olympic Sports Center, Community Culture Sports Center, neighborhood committees, Yayuncun Hospital (including 4 Community Service Centers and 4 Neighborhood Health Care Stations), etc.
- V. Members of Child Safety Working Group include representatives from Community Construction Office, schools, kindergartens, neighborhood committees, etc.
- VI. Members of Home Safety, Hygiene & Health Working Group include representatives from Yayuncun Hospital (including 4 Community Service Centers and 4 Neighborhood Health Care Stations), Women's Federation, Population and Family Planning Sector Office and neighborhood committees, etc.
- VII. Members of Occupational Safety and Health Working Group include representatives from Labor Sector Office, Detachment of City Management Supervision Brigade, neighborhood committees, etc.
- VIII. Members of Environment, Public Hygiene & Safety Working Group include representatives from City Management Sector Office, City Management Supervision Brigade, Property Companies, neighborhood committees, etc.
- IX. Members of Injury Supervision, Surveillance and Evaluation Working Group include representatives from Public Security Comprehensive Management Sector Office, Yayuncun Hospital, police station, Yayuncun Fire Brigade, Yayuncun Traffic Police Brigade, experts, etc.

Responsibility of Working Groups

- I. To attend meetings of the Promotion Committee.
- II. To participate in the formulation of specific programs.
- III. To organize residents to implement Safe Community promotion programs targeting at high-risk groups and environments, vulnerable groups
- IV. To hold regular community meeting and invite residents to resolve problems together.
- V. To carry out various activities and the popularization of safety knowledge in order

to raise residents' awareness of safety and their skills of accidental injury prevention.

VI. To integrate and properly utilize resources of human, materials and finance.

VII. To undertake other work for Safe Community promotion.

4. Indicator 2

Long-term, sustainable programs covering both genders, all ages, environments and situations

4.1. Community Public Security

4.1.1. Police Station is responsible for dealing with the danger situation in the community. Residents can dial emergency call "110" when they encounter any dangers. Polices will rush to the site in the shortest time and handle the danger situation according to Law.



4.1.2. Designating Community Full-time Policemen

One or two policemen are designated by Police Station to carry out work on public security in each residential district, such as promoting injury prevention knowledge and youth safety education, and dealing with violent cases in the region. When violent cases occurred, policemen-in-charge will conduct personal investigation and interview on the

site and then put forward some prevention proposals.

4.1.3. Neighborhood Public Security Organization

Under the direction of community policemen, neighborhood public security organized was formed to manage daily public security publicity, to organize community patrol volunteers, to provide educational guidance, assistance such as employment information for those serving their time in prison in order to avoid them to recommit a crime.



4.1.4. Electronic Supervision System

Yayuncun Community installed 96 TV supervision monitors, 1 commander center and 4 section supervision rooms. Full-time personnel keeps watch on the supervisory screen around the clock, manages close contacts with police station, reports and resolves danger situation immediately.

This system started to operate from 2001. Yayuncun Community has invested over 5,000,000 RMB to make the incessant improvement for the system.

4.1.5. Electromagnetic Door Intercom System

Yayuncun Community equipped electromagnetic door intercom system in the building gates of all residential



districts. It not only effectively reduced preventive cases in residential districts but also prevented possible human injuries and property loss.

The installment of electromagnetic door intercom system in the whole region will cost about 5,000,000 RMB contributed by estate owners, property companies, residents and governments.

4.1.6. Traffic and Fire Control Policemen Entering into Neighborhoods

Besides of public security polices permanently settled in each residential districts, traffic and fire control policemen also conducted the activities of entering into residential district, social units and schools. They promote traffic and fire control safety education targeting at high-risk groups, inspect and eradicate existing hidden risks and introduce risk prevention and evacuation knowledge by holding lectures and exhibition boards.

4.1.7. Conducting Safety Publicity Activities

Community Safety Association meets on a monthly basis to publicize community safety status and to carry out safe publicity activities of various topics in densely populated area.

Community promotes safety knowledge among residents through playing educational TV shows, publicity boards and sending out publicity materials. About 20,000 volume publicity materials have been distributed via various channels from 2005 to September 2006.

4.2. Fire Control Entering into Community

Activity of “Fire Control Entering into Community” was kicked off from May 2002.

4.2.1. To install fire control tank in key region, to examine and replace small-size fire control tank in high floor residential buildings. To ensure fire control equipment could be timely put into use in case fire occurred. In addition, to manage regular fire control equipment inspection in key fire protection units including large size shopping malls, hotels, restaurants, and amusement places, to enforce reconstruction of units with hidden risk of fire and to organize fire control safety inspection in social units and schools. Fire control safety inspection includes checking fire extinguisher, fire equipment, safe entrance of buildings, evacuation passages and stairs, etc



4.2.2. To strengthen publicity and raise residents’ awareness of fire control safety. Each community has established fire control safety publicity board putting up knowledge of how to prevent fires, how to deal with fire, etc. Residents can learn fire control knowledge when they rest and walk in the community. To hold fire control safety lectures to introduce fire extinguisher use, fire rescue and evacuation methods.

4.2.3. To promote fire prevention knowledge in various forms and at different occasions. In spring, we mobilized residents to straight out sundries in order to eradicate hidden fire risks; in summer, we give publicity to fire control knowledge ten minutes before Community Summer Evening; in autumn, we timely clear up falling leaves and teach children not to make fire. Every month, Yayuncun Fire Brigade pays visit to community and migrant workers living place to introduce fire prevention and fire rescue knowledge, and to stress the importance of fire control safety and the right use of fire extinguishers.

4.2.4. To arrange fire drills for employees in form of simulation in cooperation with enterprises. Fire drill comprises self rescue, evacuation, right use of fire equipment, etc. Fire Control Brigade arranges Fire Control Publicity Day for residents and social units once a month.

4.2.5. To train residents' ability of fire control through various channels. E.g. regularly inviting fire fighters to introduce fire first aid measures; organizing fire evacuation drills. Apart for such direct training for residents, we promote the popularization of fire control safety knowledge through neighborhood committees, enterprises and volunteers organizations.



4.2.6. To hold large-scale fire control safety publicity activity in community square on October 9th every year. To promote domestic fire prevention knowledge, workplace fire prevention knowledge, the use of fire extinguishers and other fire equipment, etc.

4.2.7. There were 49 cases of fire alarm in Yayuncun Community in 2004, including 29 fire cases in residential district and 20 in social units. It caused 10 casualties and fire loss of 500,000 RMB. There were 45 cases of fire alarm in Yayuncun Community in 2005, including 17 fire cases in residential district and 28 in social units. It caused fire loss of 50,000 RMB and no casualty.

Comparison of Fire Outbreaks in Yayuncun Community between 2004 and 2005

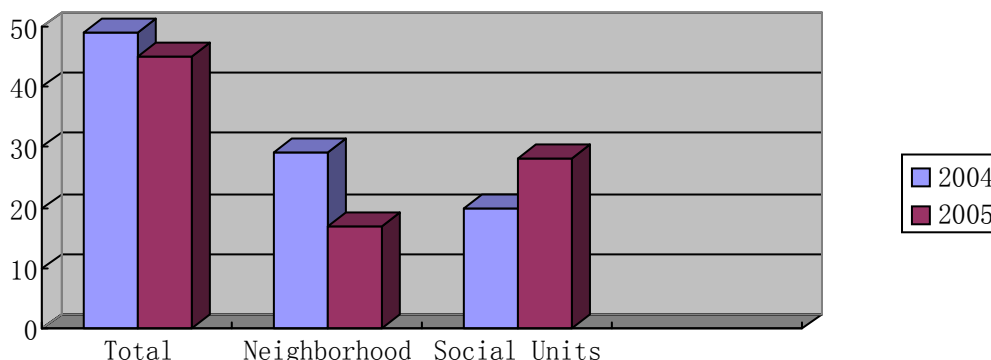

4.3. Traffic Safety Entering into Community

4.3.1. To carry out traffic safety entering into residential districts, social units and schools, to form traffic safety publicity teams, to give wide publicity to traffic safety regulation and to conduct publicity and education in social units, schools, residential districts and construction sites targeting at high-risk groups through displaying traffic accidents publicity board and sending out publicity brochures.



4.3.2. To fulfill road reconstruction. We have set up speed-limited section and caution signs at intersections, school around areas, etc, installed traffic signs, setting guide directions and signs of parking lots, no parking, no ring, etc. in the process of building roads and repaving asphalt.



4.3.3. To install publicity board that writes “No driving after drinking” in public places and restaurants. To reduce traffic accidents caused by drinking alcohol

4.3.4. Personnel of neighborhood committees install caution signs on the road after snow and organize snow sweeping and melting in order to reduce traffic accidents and injuries caused by wet road.



4.3.5. To resolve the disorder parking of bicycles. Making specific parking rack and shed for bicycle parking. Arranging bicycle in good order to avoid environment chaos and bicycle thefts

4.3.6. To hold “Popularization of Traffic Safety in Family” and “Safety Popularization in School” with joint efforts of traffic policemen. Setting “Traffic Safety Corner” in schools to introduce traffic signs and basic safety knowledge; promoting traffic safety knowledge in residential districts through traffic safety CDs, exhibition board, publicity window. We have raised residents’ awareness of traffic safety through the implementation of all kinds of publicity activities.



4.4. Anti Domestic Violence Activity

4.4.1. To set up local Women and Children Legal Rights Protection Team

On the second half of 2004, Yayuncun Women and Children Legal Rights Protection Team was formed. Composition of the Protection Team was made of representatives from related departments of Yayuncun Community Office, police stations, judicial and law

institutes, labor union, Yayuncun Hospital and Women’s Federation of each neighborhood committee. It formulated “*Safe Family Creation Implementation Program*”. The Protection Team holds the meeting periodically.

4.4.2. To establish and perfect overall protection network

We set up Women and Children Legal Rights Protection Station with composition of community office and neighborhood committee. We mapped out the system of dealing with complaints by letter and visit and the Station working mechanism. The Station is responsible for specific work such as complaints reception, recording, and reporting, and disputes intermediation.

4.4.3. To set up “Anti Domestic Violence Service hot line”

Publicizing ten service hot lines of Community Office and neighborhood committee to the society, developing anti domestic violence working mechanism with concerted efforts of volunteer organizations, law offices and other social unions; Community Health Service Center delivers psychological service and medical aid for all domestic violence sufferers to reduce their physical and spiritual hurts.

4.4.4. Each neighborhood committee built Women Protection Shelter Center to provide psychological consultation, legal defend, legal aid and medical treatment service. So far, it has protected three women who suffered domestic violence.



4.4.5. Forming information collection and intermediation group with resident group leaders and building gate master as members. Carrying out regular psychological health guidance and women’ legal aid to straighten out and resolve home disputes in order to create stable community rights protection network.

4.4.6. Editing domestic violence protection and deterring knowledge such as “Teaching You Several Tricks” , printing and sending out publicity leaflets such as “Marriage Law and Women and Children Rights”, etc. Inviting experts and lawyer to conduct onsite consultation and answer questions during Women Right Protection Week and Publicity Month.

4.4.7. Stressing training and education and improving the comprehensive quality of rights protection group.

Community Women’s Federation devotes efforts on trainings by inviting experts to hold a lecture, organizing exchange meetings and classes in order to enhance the comprehensive quality of staff working in local Women’s Federation and Community Right Protection Groups at different levels.

According to the result of data surveillance by Yayuncun Women’ Federation in 2004 and 2005, there were 27 cases of domestic violence in 2004, 9 cases in 2005 decreased by 66.7%; only 2 cases on January – June 2006.

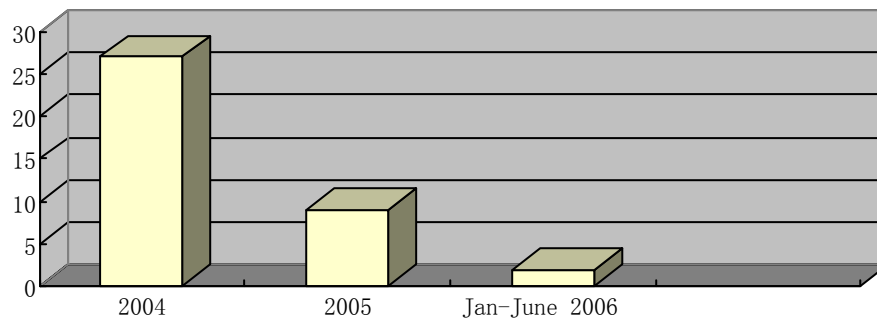

Comparison of Domestic Violence Cases in 2004-2006

4.5. Home Safety

4.5.1. Publicity team was formed with members made up of personnel from Community Office, neighborhood committee and volunteers. It promotes home safety knowledge by home visiting and sends out 6,000 home safety publicity brochures and leaflets to residents free of charge.

4.5.2. We make residents know risk resources in daily life through putting up safety knowledge wall map and warm notice on corridors and adopt prevention measures. Residents might adopt preventive measures for possible accidents such as electric and gas safe use, fire and blast prevention, the habit of closing door and windows, cutting water, electricity and gas when leaving home.

4.5.3. Community Office invites technical staff from Power Supply Bureau and gas brigade to hold talks on home appliances and gas safe use. Over 600 residents attended the talks.

4.5.4. We conducted electric appliances and gas facility inspection for over 500 families in 2005.

4.6. Community Cultural and Sports Center

Covering the area of 2,600 square meters, Yayuncun Community Cultural and Sports Center is facilitated with nearly 30 service programs and over 10 cultural and sports teams. E.g. Community Library covers the area of 300 square meters with the investment of about 50,000 RMB. There, we have set special column in adult section, added safety education books and built safety conundrum palace in children section; students from Choral Speaking Class read poems “Ten Safety Attention”; students from Art and Calligraphy class express their understanding of safety through their products; Patriot Art Ensemble performs safety education show opusculum “After Traffic Accident” to publicize first aid knowledge; residents can also experience safety training in the comprehensive training room to achieve safety education through playing sports and games.

4.7. Improving road safety

The western part of Yayuncun Community is the old residential district with most roads built in 1950s-60s. The broken and growl roads in the region are easy to accumulate water in raining day and cause injury accidents in snowing day. Its eastern part is the nest of residential districts constructed in 1990, where traffic jam and accidents often happens. Surface lubricity of pavements mostly cause fall injuries in residential districts. In recent years, community mobilized the concerted contribution of society to conduct a large-scale reconstruction for residential district roads and pavements. Those rebuilt residential districts include Anyuanbeili, Anhuili, Anxiangli, 4th and 9th Huayanbeili, Huayanbeili, Shijiahuaozhi, departments of China Academy of Science, Geological Research Institute of Chinese Earthquake Bureau, etc.; reconstructed roads are Huatingxi Street, Huatingnan Street, Anxiangdong Street, Anxiang Road.



Roads before and after Rebuilt

With the investment of 9,590,000 RMB, we reconstructed pavements of 65429 square meters and roads of 35,018 square meters and blind walkway of 2000 square meters.

4.8. Quiet Residential district

People living in the city are always distributed by all kinds of noises, especially for the elderly and children. It is easy to suffer from neurasthenic and other diseases if people live in the noisy environment for long time.

Since 2003, Yayuncun Community regarded building “quiet residential districts” as objective and formulated a set of programs and criteria. E.g. forbidding house renovation at noon or in the night, forbidding the using of high noisy instruments such as electric drill, saw, etc during the holidays, restricting the use of hi-fi loudspeaker, installing sign of “no tooting”, motor vechiles stopping engine when entering into residential district in the night, setting special parking lots, limiting car alarm db, avoiding pet noise, prohibiting market construction 50 meters within residential district, advocating care between neighborhood.

4.9. Safe Production

Under the leadership of Safe Community Promotion Committee, Working Group on Safe Production carries out responsibility of safe production. Enterprises established special department of safe production and formed completed systems and emergency handling system.

4.9.1. To sign safe production responsibility book with all enterprises and clarify that corporate artificial person is the first one in charge of production safety. There was no accident of safe production occurred in the community since 2004.

4.9.2. To identify and analyze risk resources. Holding training classes for full-time safe guards; formulating accidents preventive measures; organizing drills targeting at chemical risk products production, storage and sales units; strengthening supervision on construction sites, gas station, etc.

4.9.3. To organize “Safe Production Month” and distribute safe production publicity materials in accord with Safe Production Law of People’s Republic of China, Beijing Safe Production Regulations

4.10. Community Disputes Mediation

Domestic conflict or quarrel among residents sometimes happens in daily life by different reasons. It might lead to dispute or even violence and bring about hidden risk to community safety.

4.10.1. Yayuncun Judicial Bureau and 10 neighborhood committees set up 11 People’s Mediation Committee and 28 mediation groups before the year of 2004. In 2005, People’s Mediation reached 46. Large social unites and property companies also set up mediation committees. Now there are total of 480 mediators, 100 information providers. Each mediation committee is facilitated with mediation room.

4.10.2. Civil mediation directors, mediators and information providers of Neighborhood Committees have all passed trainings. There were 5 five national trainings and 7 professional trainings with 500 person-times in 2004; there were 28 national trainings with 1,200 person-times in 2005.



4.10.3. 159 disputes were mediated in 2004 and 156 were resolved with the rate of 99.9%; 233 disputes were mediated in 2005 and 223 were with the rate of 95.6% .

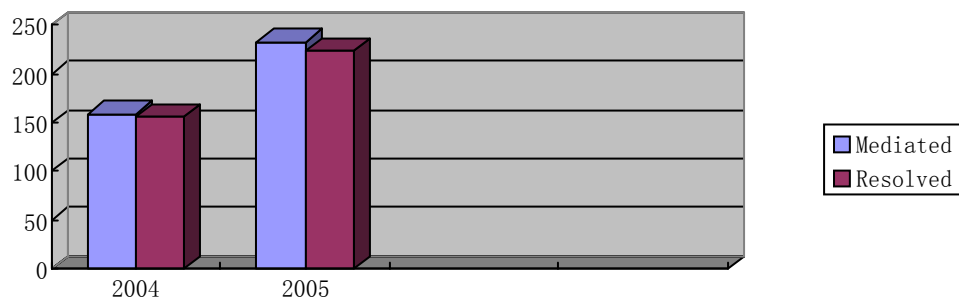

Comparison of Mediation between 2004 and 2005

4.10.4. We investigate residents within community by five times and resolved 36 disputes; We investigate residents within community by nine times and resolved 14 disputes. It has stabilized residents' emotions, avoid disputes becoming acute and prevent conflicts and injury.

4.11. Psychological Consultation Service

Yayuncun Hospital and Community Health Service Center are the professional departments to conduct psychological consultation and suicide prevention. They started to provide treatments for psychological patients from June 2002.

4.11.1. Yayuncun Hospital makes records for mental illness and psychological abnormality patients. 22 mental disease supervision groups were formed to inspect patients at scheduled time, to hold trainings on prevention and cure, to master state of patients' illness and well manage evaluation. For those lost confidence because life set back and those intend to commit suicide, we help them walk out psychological shadow and build up positive attitudes toward life through timing treatment by psychological experts.

4.11.12. To release students' pressure. Health Service Center established psychological service rooms in two primary and middle schools in order to help hundreds of students resolve their psychological problems and build up positive active personality.

4.12. Promoting Public Hygiene and Home First Aid Knowledge

4.12.1. Community Medical Treatment Service Network

In 2005, with the support of Yayuncun Community Medical Treatment and Health Center, integration of resources and coordination, Yayuncun Public Hygiene Management Committee established Community Health Care Stations and invested 300,000 RMB for renovation and reconstruction. The station is tasked to establish and perfect emergency resources storage such as medical first aid goods and infectious diseases prevention, to take injury prevention as priority, to deal with emergent public hygiene affairs and to deliver medical and health services for the elderly. Currently, there are 1 Medical Health Service Center and 4 Health Care Stations in Yayuncun Community.



4.12.2. Medical Rescue Trainings

On March 21st, 2005, the inauguration ceremony of "Humanistic Olympic Games Entering into Community" & "Humanistic Olympic Games Large Class" was held in Beijing International Convention Center, Yayuncun Community, with the participation of over 1,000 volunteers. On this occasion,



Red Cross Volunteers Service Team was also formed. On May 15-16th, 2005, we organized trainings for rescuers and invited experts from Red Cross Association to hold lectures on heart and lung anabiosis, injury rescue, etc. and conduct onsite simulation training. Participants include teacher of local kindergartens, schools, directors of neighborhood committees, community volunteers and representatives of social units, and stewards on their vocation in Beijing of Netherlands Airline Company. Over 30 persons attained Rescuer Training Certificate.

We held health talks of various kinds by 15 times in 2005 with 2,000 person-times.

4.12.3. Elderly Health Records

Community Civil Administration Sector Office and Medical Service Center make health records for the elderly above age 60 in each health service station, conduct data surveillance and following up services.

4.13. Medical Waste Disposal

Well medical waste disposal management is very important for preventing diseases spread, protecting environment and ensuing human health.

Yayuncun Hospital formulated 15 regulations on medical waste disposal. All staff takes 6 training hours every year. In 2005, training attendants reach 193. It also conducts medical waste management training for staff of community medical treatment service center and individual doctors

Yayuncun Hospital newly built the medical wastes store area and appointed full-time personnel to take charge of reclamation records. The store area is installed with caution directions and transport routes, e.g. edge tools putting into edge tool boxes, infectious disease waste putting into yellow bags. This will prevent injuries possibly caused by medical waste.

Yayuncun Hospital invests about 50,000 RMB for medical waste disposal.

5. Indicator 3

Programs that target high-risk groups and environments and programs that promote safety for vulnerable group

5.1. Child and Youth Safety Education

5.1.1. “Traffic Safety” Starting from Children

Yayuncun Kintergarten invested over 80,000 RMB to build “Child Traffic Safety Education Demonstration Base”. It set up micro traffic simulation system facilitated with overpasses, walkway, zebra crossing, blind pavement, crossroad, traffic light and all kind of traffic signs. Traffic policemen are invited to carry out onsite traffic safety knowledge, provide simulation cars, uniforms, armbands and badges to children to create the imaginary setting for children, to instill traffic knowledge into in playing games and to

bring along parents and family members to consciously observing traffic regulations. Policemen participate in the traffic simulation activity with children on every Wednesday.



5.1.2. “Environment Safety” Starting from Children

Yayuncun First Kindergarten invested 340,000 RMB to establish “Children Environment Protection Safety Education Base”. Setting different simulation environment according to age characteristics, conducting “noise harm”, “environment safety” education, making children have awareness of environment protection from childhood.

5.1.3. “Fire Control Safety” Starting from Children

Yayuncun Second Kindergarten invested 20,000 RMB to establish “Children Fire Control Safety Education Base”. Inviting fire policemen to demonstrate fire extinguishing, emergency aid; teaching children to recognize evacuation signs and routes through publicity paintings and fire control chess; installing emergency evacuation places and organizing emergency drills.

5.1.4. Community Safety Cultural Activity

To carrying out “various, helpful and interesting” cultural activities in Community Cultural and Sports Center to enrich children safety cultural life; Teaches and students reading “Ten Attentions of Safety” targeting community children, rebuilding children training room as children emergency evacuation training camp, installing evacuation training sport appliances to achieve education goals through sports.

5.1.5. Injuries often occur among students after class especially during summer and winter holidays. To solve this problem, we arranged winter and summer classes. Dozens of children in the age group of 6-12 make up a class to learn paintings, calligraphies, playing billiard, chess, designing board newspaper, playing games and watching safe education videos with staff and volunteers.

5.2. Youth Reproductive Health Education

Yayuncun Community invites experts to arrange sex and reproductive health courses in each high school to help teenagers understand adolescence characteristics and knowledge about sex and reproductive health. They also hold lecture on “Unscrambling adolescence password and protecting teenagers’ health”, in which experts will introduce sex knowledge and characteristics for children in adolescence and answers parents’ questions to help them better understand and further communicate with their children.

5.3. Elderly Health Promotion Center

5.3.1. Yayuncun Elderly Health and Safety Promotion Center built Safety and Health Education Classroom to promote safety education targeting at elderly home safety, eating and drinking safety, mobility safety, psychological health, environment hygiene, and to organize residents to participate in various healthy knowledge lectures.



5.3.2. Safety and Health Education Demonstration

Demonstration unit is equipped with home appliances such as microwave oven, to vivid display healthcare foods, food safety, and appliances safe use and first aid knowledge.



5.3.3. Providing healthy, legal and psychological consultation for elderly, playing health education videos and conducting regular health examination for the elderly.

5.4. To take care the elderly

5.4.1. Working Committee for the Elderly

Yayuncun Community formed Working Committee of the Elderly Work. Members of the Committee often make investigation in residential district to find out needs of the elderly and try their best to solve problems of the elderly.

5.4.2. Formulating seven working system for the elderly, namely, basic information recording for the elderly, elderly rights protection and medication, elderly cultural and sports system, assistance for empty-nest elderly, taking care for the elderly, aid for the elderly with special difficulties and education for the elderly.

5.4.3. Making records for the elderly. We adjust records of the elderly above age 60 and introduce computer to achieve integrated network management for elderly work.

5.4.4. Promoting the Elderly Law during the activities of community and neighborhood committee. Publicizing examples in life related to law on publicity board and advocating filial piety and protecting legal rights for the elderly.

5.4.5. Enriching cultural and sports activities for the elderly. There are elderly classes, elderly section in reading rooms, chess rooms, painting and calligraphy rooms, chanting rooms available for the elderly built by 10 neighborhood committees. Various cultural and sports team such as Patriot Art Ensemble and fashion dress performance team are made up of the elderly and hold regular and rich activities.

5.4.6. Volunteers signed assistance agreement with 80 empty-nest elderly. Volunteers service teams provide assistance for the elderly in shopping, seeing a doctor and home

keeping; send guaranteed income supplement and medical charges to the elderly families timely; install “120” door rings for 4 elderly and deliver time home treatment for 1 empty-nest elderly.

5.5. Creating “Warm Home” for the Handicapped

Yayuncun Community Handicapped Association started the project of building warm home for the elderly according to indicators in 2005. The project is tasked to organize departments concerned to inspect service facilities for the handicapped in the community, to perfect fundamental work for the handicapped, to put into effect of all kinds of benefit policies and to organize activities of assistance for the handicapped.

5.6 Guidance for the Handicapped Healing

5.6.1. The handicapped healing clue investigation

Working Committee of The Handicapped Healing Investigation comprises principals of Community Office, hospital, civil administration and the Handicapped Association. The Committee carries out the responsibilities for organizing, coordinating and implementing healing needs of the handicapped in the region. They conducted survey for 2,400 handicapped through sending out questionnaires targeting basic information, state of deformity, severity of injury and healing needs. There are 466 handicapped in Yayuncun Community including 299 male and 167 female by April 2006. Triage categories of deformity include 216 of body, 28 of eyesight, 54 of audition, 79 of brain, 76 of mental and 13 of comprehensive symptom. Based on evaluation, we input the healing needs of 373 handicapped into computer.

5.6.2. The Handicapped Healing Guiding Station

The Handicapped Healing Guiding Station set up records of name, information, and trainings of the handicapped healing. Yayuncun Hospital selected 3 full time doctors to take charge of daily healing trainings and guiding. Healing training programs are made out targeting at the state of every one. They carried out 563 person-times healing guidance and comprehensive treatment for the handicapped with 95% effectively healed, 86% notably healed and 29 persons recovered. Huayanliju Neighborhood Committee investigated 460,000 RMB to the Station and purchased worthy of over 40,000 RMB of healing appliances, enlarged the floor area from 24 to 36 square meters and improved the healing environment for the handicapped.

5.7. Non-obstacle Facilities Construction

Yayuncun Handicapped Association arranged a survey on passage obstacles targeting at the handicapped living in high-floor building and rebuilt “non-obstacle” facilities in 4th Huayanlixiju, 3rd Anyuanliju, 1st Anxiangli and 2nd Anhuiliju with the total investment of 110,000 RMB. Jingmin Neighborhood Committee installed 17 armrests in corridors of the ground floors to ensure the safe and convenient transport for the elderly and the handicapped.



5.8. Migrant Workers Education

Migrant workers are the vulnerable group as they come from far regions or countryside and lack city life experience. Therefore, it is more important to take care of them.

5.8.1. To conduct publicity and education



Conducting sustainable publicity education for migrant workers through publicity window, roving exhibition and sending out over 2,200 publicity materials; popularizing public security, fire control, traffic safety, and labor employment law; raising migrants' awareness of law and self protection.

5.8.2. To hold Safe Knowledge Trainings

Holding safe knowledge trainings and introducing traffic safety regulations, fire rescue, evacuation methods, and construction sites fire safe use, electricity use and other safe production knowledge.

5.8.3. To provide services

Providing migrants workers with services of job introduction, technical trainings, special qualification application, children enrollment, residence transformation, labor rights protection, etc.; helping them solve difficulties in life and work; setting up house renting agencies, conducting renting house management; providing legal consultation and aid and protecting their legal rights.

We played movies at construction sites by 25 times with audiences of 3750 person-times.

5.9. To Take Care Low income Groups and Well Manage Social Aid

5.9.1. Low income family status management

On the first half of 2005, we made a survey in order to have a clear picture of low income families and to ensure the baseline for low income residents. There were 123 low income families and 253 low income persons. Government allocated 334,635.42 RMB subsidiaries to low income groups, 19,992 medical subsidiary to 10 medical aid applicants. 3 families applied low income and house renting families.

5.9.2. Care and assistance

Community leaders visit those low income families, retirees, the handicapped, subsidized families, unemployed families and families on the edge of guaranteed income supplement every year. In 2006 we visited and condoled 510 persons with funds and goods worthy of 127750 RMB, including goods of 9,600 RMB for 32 persons sent by Love Home.

5.9.3. Making full use of "Love Home" and launching "Five Assistances" project

In 2005, we put forward "Five Assistances" project that provides material, physical, technical and intellectual assistances targeting at vulnerable groups. With the survey on baseline families, we made records for 12 families with difficult caused by diseases, 4

low income families, 6 families with several family members handicapped. Community Love Home sent out 78 aid cards worthy of 18,750 RMB in the first half of 2006. In physical assistance, we conducted healing trainings for 10 handicapped with the support of Yayuncun Hospital and provided technical trainings and assistance in children enrollment for low income families.

6.Indicator 4

Program that document the frequency and causes of injuries

6.1. To set up injury records

Since 2005, each functional department made injury records system. See set records below:

- Public Security Management Records
- Fire Incidents Records
- Traffic Incidents Records
- Yayuncun Hospital Traumatic Injury Treatment Records

6.2. Injury Analysis

6.2.1. Public Security Cases Analysis

Yayuncun Police Station dealt with 386 criminal cases in 2004 that decreased by 7% than 414 criminal cases in 2003. The number of criminal cases in 2005 was 339 decreased by 12.18% than that of 2004.

| Month Types | Ja n. | Fe b. | M ar. | Ap ri. | M ay | Ju ne | Jul . | Aug. | Se pt . | Oc t. | No v. | De c. | Total |
|---------------------------|----------|----------|----------|-----------|---------|----------|----------|------|---------------|----------|----------|----------|-------|
| Robbery | 1 | | 2 | 2 | 2 | | 2 | | 7 | 3 | | 2 | 21 |
| Snatching | 2 | | 1 | 1 | 2 | | | 2 | | | | 3 | 11 |
| Sexual Crime | 1 | | | | 1 | | 1 | | | | | | 3 |
| Theft, House | 4 | 1 | 5 | 2 | 7 | 7 | 6 | 10 | 13 | 3 | 6 | 13 | 77 |
| Robbery, House | | 1 | | | | | 1 | | | | | | 2 |
| TFV | 3 | 1 | 2 | 4 | 2 | 4 | | 1 | 1 | 1 | 2 | 1 | 22 |
| TCWA | 7 | 1 | 6 | 8 | 16 | 6 | 4 | 12 | 4 | 4 | | 6 | 74 |
| Others | 13 | 12 | 7 | 8 | 9 | 17 | 11 | 13 | 9 | 15 | 9 | 6 | 129 |
| Total | 31 | 16 | 23 | 25 | 39 | 34 | 25 | 38 | 34 | 26 | 17 | 31 | 339 |

*TFV: Theft From Vehicle

*TCWA: Unauthorized Taking of Motor Vehicle

Statistical Table of Reported Crime in Yayuncun in 2005

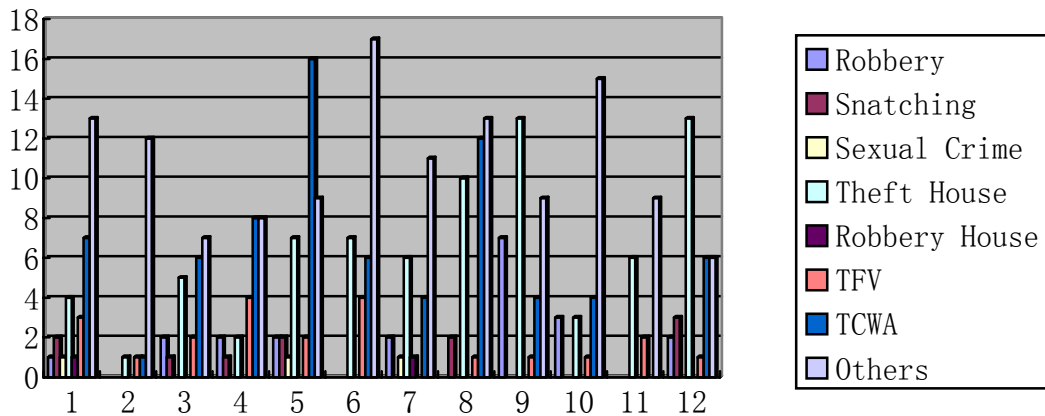

Reported Crime in Yayuncun in 2005

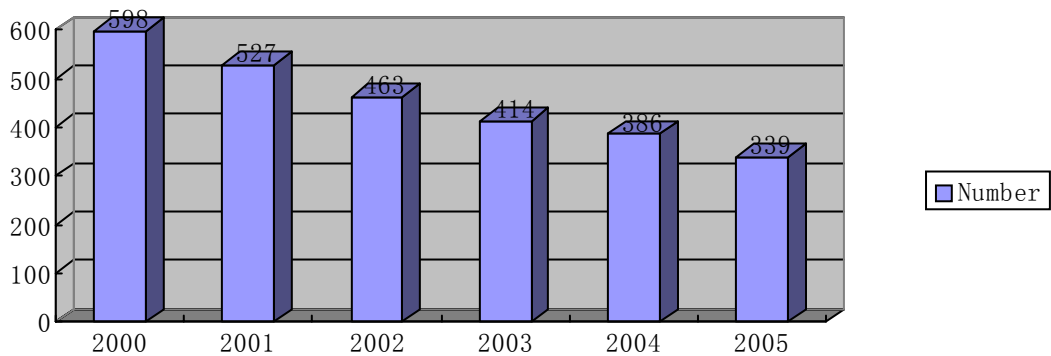

Comparison of Reported Crime by Year

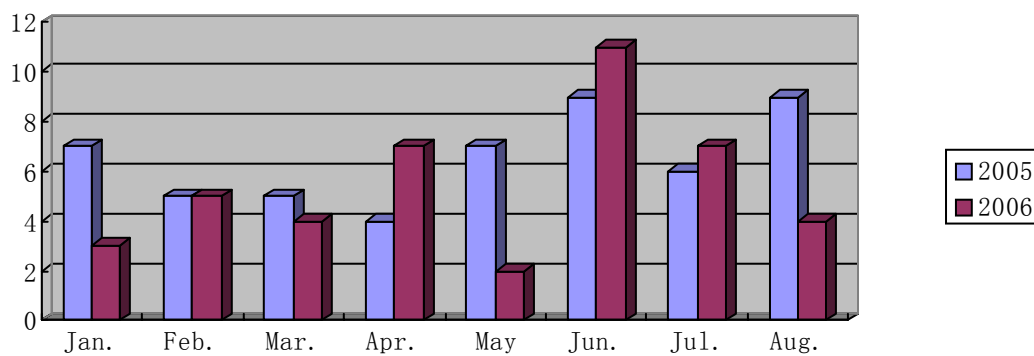

Comparison of Reported Crime on Jan-Aug. 2006 and the Corresponding Period of 2005

There were 52 house theft cases on Jan-Aug, 2005 and 43 house theft cases on Jan-Aug, 2005, decreased by 17.31%.

6.2.2. Fire Accidents Analysis

In 2004, Yayuncun Fire Brigade was sent out by 49 times. There were two serious fires in 2004: one in Microelectronics Center of CAS at 16:18, 25th March 2004 and the other in Jingmin Mansion at 15:56, 9th June 2004.

Causes of Fire Analysis:

Fire outbreaks reflected the lack of fire control safety awareness among residents. There are about ten fires caused by improper use of home gas. In particular, the fire in Jingmin Mansion was caused by poor fire control awareness of builders. There were several fires caused by the disorder arrangement of sundries.

Since 2005, fire outbreak manages a decrease tendency. 45 fires occurred in 2005 and decreased by 8.16% than 49 fires in 2004.

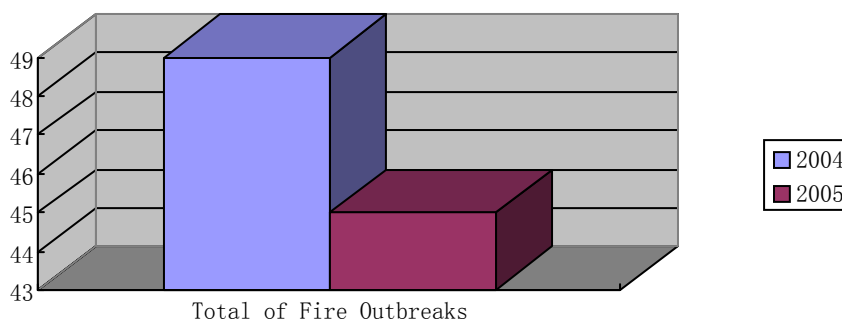
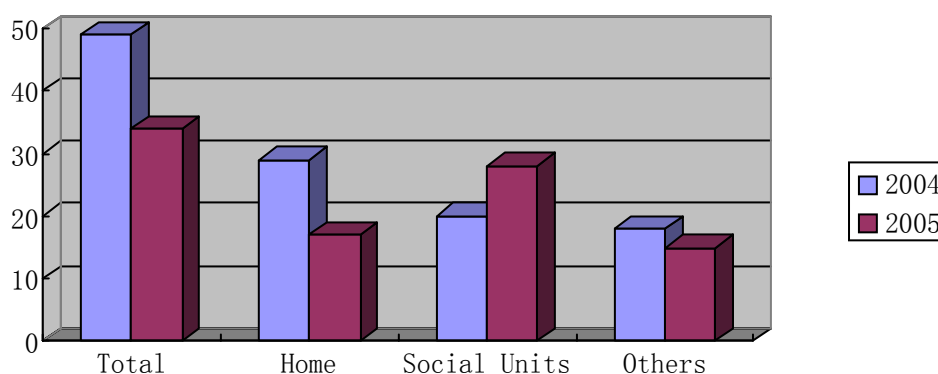

Comparison of Fire Accidents between 2004 and 2005

6.2.3. Traffic Accident Analysis

36 traffic accidents occurred in 2001 with 36 casualties, 39 traffic accidents occurred in 2002 with 42 casualties and 47 traffic accidents occurred in 2003 with 50 casualties. (See table below)

| <i>Time</i> | <i>2001</i> | | <i>2002</i> | | <i>2003</i> | |
|---------------------------------------|-------------|------------|-------------|------------|-------------|------------|
| | Cases | Casualties | Cases | Casualties | Cases | Casualties |
| <i>Non Motor Vehicle on main road</i> | 16 | 16 | 11 | 11 | 14 | 14 |
| <i>Pedestrians out walkway</i> | 11 | 11 | 12 | 12 | 15 | 15 |
| <i>Disobey traffic sign/light</i> | 9 | 9 | 16 | 19 | 18 | 21 |
| <i>Total</i> | 36 | 36 | 39 | 42 | 47 | 50 |

Number of Casualties by Causes in 2001 - 2003

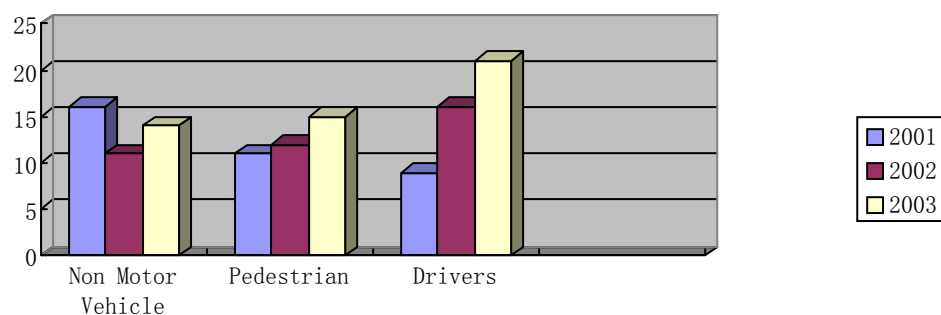

Number of Casualties by Causes in 2001 - 2003

The profile above shows that most traffic accidents were caused by obeying traffic regulation and lack of safety awareness. Non motor vehicles, pedestrians and drivers were high-risk groups. During the investigation, 85.6% interviewees agreed that traffic accidents could be avoided. Most interviewees also thought that safety publicity and related training were important measures to effectively prevent injuries. Therefore we strengthen efforts on traffic safety publicity and education and took enhancing people's safety awareness as major measure to reduce traffic injuries.

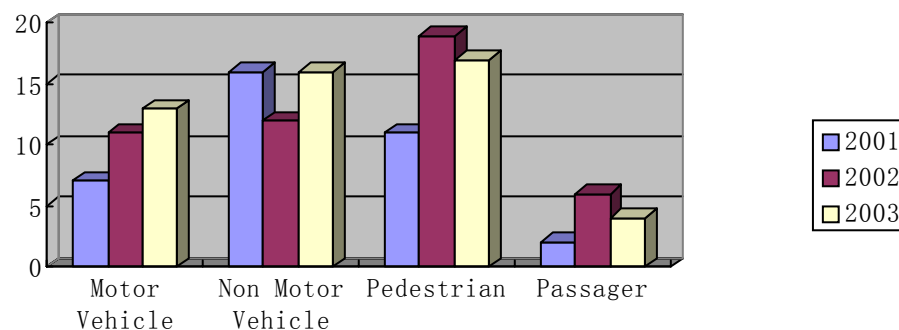

Number of Casualties by Causes in 2001 - 2003

Above profile indicates that the injury rate of non motor vehicle user and pedestrians

were rather high. Therefore non motor vehicle user and pedestrians were high-risk groups in traffic safety.

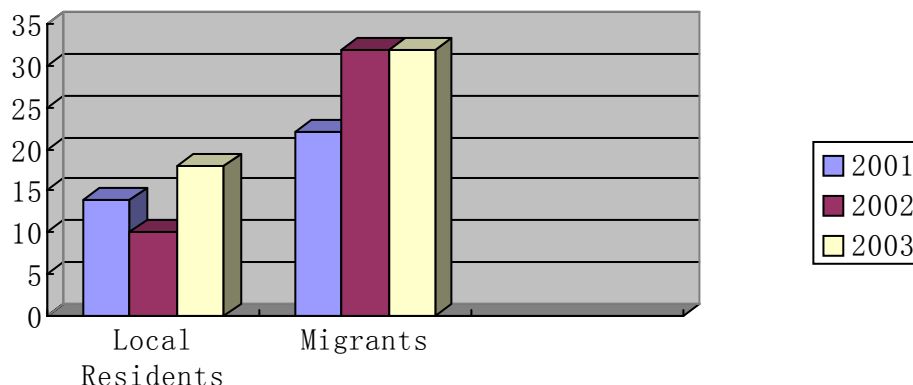

Number of Casualties by Composition in 2001 - 2003

Among traffic accident casualties, floating population is the vulnerable group for traffic accidents. Therefore we take floating population as high-risk group in implementing prevention measures.

Number of Traffic Accidents with Casualties in 2005

| Month Type | J a n . | F e b . | M a r . | A p r . | M a y | J u n e | J u l . | A u g . | S e p . | O c t . | N o v . | D e c . | Total |
|-------------------------|---------|---------|---------|---------|-------|---------|---------|---------|---------|---------|---------|---------|-----------|
| Injured (Person) | 4 | 3 | 4 | 5 | 5 | 6 | 3 | 4 | 6 | 2 | 3 | 2 | 47 |
| Death (Person) | 0 | 0 | 0 | 0 | 0 | 0 | 0 | 0 | 0 | 0 | 0 | 0 | 0 |

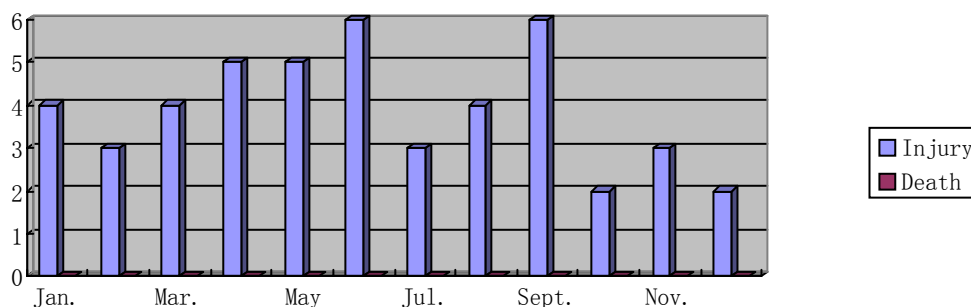

Casualties of Traffic Accidents in 2005

The above profile indicates the downtrend of traffic accidents and no casualty in 2005.

6.2.4. Hospital Emergency Treatment and Traumatic Injury Treatment Analysis

Yayuncun Hospital made detailed records for clients and their treatment, such as family address, age, gender, diagnosis of illness, etc. Based on these records, local injury and accident recording system was gradually perfected. We might analyze potential injury causes and apply for the implementation of effective prevention measures.

Yayuncun Hospital Traumatic Injury Treatment 2004-2006(Jan.-Sept.)

| Time \ Type | 2004 | 2005 | 2006 (Jan.- Sept.) |
|-------------------|------|------|--------------------|
| Number of Clients | 650 | 670 | 512 |

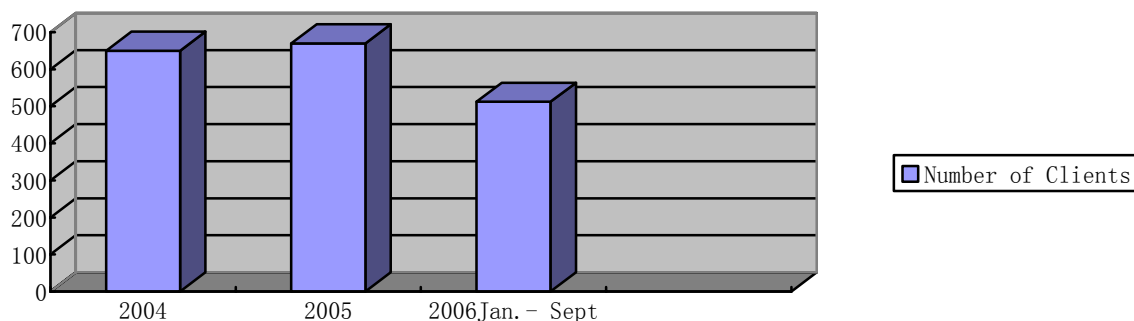

6.3. Home Water, Electricity and Gas Use Safety Visit

On January 2005, Social Comprehensive Management Department formed publicity team with members of Working Committee of Safe Community Promotion, staff of working groups related and volunteers to promote home safety by home visiting in order to find out risk factors and to help families to eradicate hidden risks.

The home visiting involved all residents in Yayuncun Community and achieved zero accidents of home water, electricity and gas use.

7. Indicator 5

Evaluation measures to assess their programs, processes and the effect of change

Under the direction of Safe Community Promotion Committee, 9 working groups safety promotion formulated corresponding safety promotion programs in accord with their work in different fields. They stress safety promotion for the elderly and children and environment construction, regarded traffic safety and fire control safety as top priority, set up effective supervision and management mechanism in line with local condition. Working group meet regularly to review the process of programs, discuss next-step work plans and adjust program based on work reports so as to promote the progress of the Safe Community project as schedule. Meanwhile, through “Residents Forum”, “Residents

Express”, hotline, feedbacks of neighborhood committees, etc. they timely finger out deficiencies and use it to guide future work. Evaluation working group with members made up of government leaders and experts supervise and inspect the processes of the Safe Community project and evaluate the whole progress. We set up supervision awards mechanism and long-term effect management mechanism, combine establishing Safe Community with building large-scale regional safety layout. We make summarization and regulation incessantly, gradually pushing forward the project from part region to the whole community, from elementary level to high grade so as to the steadily development

8. Indicator 6

Ongoing participation in national and international Safe Communities networks

Yayuncun Community has been actively participating in national and international Safe Community Conferences and exchange activities since the implementation of the project of Safe Community on October 2004.

- On April 2005, Yayuncun Community attended “Safe Community Promotion Experience Exchange Conference” organized by China Occupational Health and Safety Association.
- On October 2005, Yayuncun Community undertaken “Safe Community Criteria and Implementation Symposium” organized by China Occupational Health and Safety Association.
- On March 2006, Yayuncun Community attended the designation ceremony of Youth Park Safe Community in Jinan City, Shandong Province, and International Safe Community Symposium.
- On April 2006, Yayuncun Community attended the 15th International Safe Community Conference in Africa.
- On September 2006, Yayuncun Community attended “National Safe Community Construction Symposium” in Beijing, made a speech at the conference with two papers involved in the conference paper collection..
- On December 2004-March 2005, Yayuncun Community organized people from safety promotion working groups to investigate Tai Po and Kwai Tsing Safe Communities in Hong Kong by many times.
- Yayuncun hosted the investigation delegation Mr. JOON PIC CHO, Chairman of WHO Safe Communities Networks of Asia, and the delegation Deng Huasheng, Secretary General of Hong Kong Occupational Safety and Health Bureau.

9. Objectives of Sustainable Promotion in accord with Safe Community Indicators

Injury is the fifth largest causes of death in China. Every year nearly 800 thousand of people die of various injuries and at least 50 thousands of people suffer from injures. Children, youth and the elderly are the most vulnerable groups that are easy to hurt by

injuries. Under the guidance of WHO Collaborating Centre on Community Safety Promotion and China Occupational Health and Safety Association, Yayuncun Community will make unremitting efforts on implementing safety promotion programs and injury prevention measures with the concerted efforts of Yayuncun Safe Community Promotion Committee, enterprises and social units.

Therefore, Yayuncun Safe Community Promotion Committee maps out objectives of sustainable promotion as below in cooperation with our partners.

9.1. To improve community environment and fire control mechanism and measures; to rebuild roads and promote safety knowledge; to initiate more measures for safe production and injury reduction; to further conduct domestic violence prevention.

9.2. To further rebuild various facilities for avoiding injury and accident among children and youth and ensuing safe outdoor activities for high-risk groups; to enrich entertainment activities for residents especially for the elderly; to stress assistance work for the handicapped such as learning and seeking more healing treatment measures, calling on the whole society to help the handicapped; to help low income groups get rid of poverty by all means.

9.3. To seek more effective measures for injury and accident surveillance and to set up an injury and accidents recording system based on daily records and large-scale surveys.

9.4. To further perfect management system, to clarify individual responsibilities, to define awards regulation, and to implement supervision for evaluation measures to assess our programs, processes and the effect of change.

9.5 To actively participate in national and international Safe Communities networks and to gain assistance and guidance.

In recent two years, Yayuncun Community made wide efforts on promoting injury, accident and violence prevention. Local government, corporations, civil administration departments, private enterprises not only work hard at their own position but also set up close partnership and made great contribution to safety programs promotion.

Yayuncun Safe Community Promotion Committee hopes that people will enhance safety awareness and mutual influence on injury, accidents and violence prevention. The Promotion Committee and our partners selected the aspects below as priorities of our work in the future

- Injury and accidents prevention measures that target children and youngsters
- Injury and accidents prevention measures that target the elderly
- Traffic safety and fire control safety
- Record and evaluation mechanism

In line with 6 indicators for Safe Community, we have clarified in this application that working groups carry out the responsibilities of coordinating, investigating and drawing up programs and measures so as to reduce injury and accident in every aspects.